

Flow monitoring
Immersion sensor with integrated processor
FCS-N1/2A4-AP8X-H1141

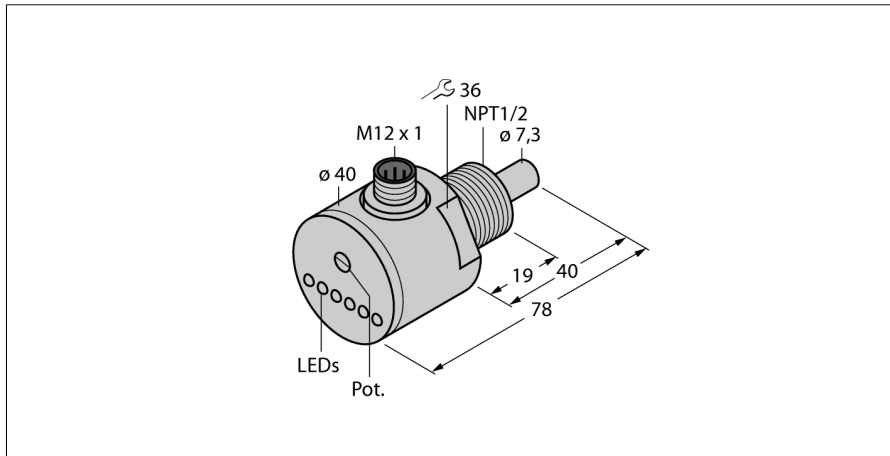

- Flow sensor for liquid media
- Calorimetric principle
- Adjustment via potentiometer
- LED band
- DC 3-wire, 19.2...28.8 VDC
- NO contact, PNP output
- Connector device, M12 × 1

Wiring Diagram

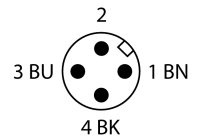
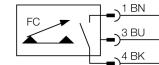

Type designation	FCS-N1/2A4-AP8X-H1141
Ident-No.	6871004
Mounting conditions	Immersion sensor
Operating voltage	19.2...28.8 VDC
Short-circuit protection	yes
Voltage drop at I _e	≤ 1.5 V
Housing material	Stainless steel, V4A (1.4571)
Max. tightening torque housing nut	30 Nm
Electrical connection	Connectors, M12 × 1
Protection class	IP67
Packaging unit	1
Switching state	LED chain, Green/Yellow/Red

Functional principle

Our insertion - flow sensors operate on the principle of thermodynamics. The measuring probe is heated by several °C as against the flow medium. When fluid moves along the probe, the heat generated in the probe is dissipated. The resulting temperature is measured and compared to the medium temperature. The flow status of every medium can be derived from the evaluated temperature difference. Thus TURCK's wear-free flow sensors reliably monitor the flow of gaseous and liquid media.